

SX Series

TELESCOPIC BOOM LIFTS



Customer-Preferred Controls



Pin-less Axle Extension for Faster Setup



Large Operator Work Platform

110SX
110SXJ
120SXJ

www.jlg.com



Proven Winners That Keep You Moving Ahead

Continuing a proud tradition, JLG offers the most rugged, reliable telescopic boom lifts in the industry — with the JLG Models 110SX, 110SXJ and 120SXJ. JLG has built on a design that has been proven on the most demanding high-reach applications up to 110 ft. (33.53 m) and 120 ft. (36.58 m), respectively. You can count on getting the dependability that keeps you moving, plus valuable standard features such as the new pin-less axle system and the Extend-A-Reach articulating boom section. An updated platform and operator controls (600 series style) delivers improved operating convenience.



110SX & 110SXJ

Rediscover the enhanced Models 110SX and 110SXJ telescopic boom lifts for applications up to 110 ft. (33.53 m). They're still the standard for multi-function operations on docks, aircraft hangars, construction, industrial or other job sites.

Features & Advantages

- Pin-less axle extension system for faster, more efficient setup
- Standard four-wheel drive
- Customer-preferred controls
- Spacious 8 ft. (2.44 m) platform provides comfortable work area
- Faster lift and lower speeds for improved productivity
- Rugged square steel platform tubing for enhanced durability
- Diesel powered engine options
- Superior boom design for an optimum strength-to-weight ratio
- 110SXJ features a 10 ft. (3.05 m) Extend-A-Reach articulating jib
- 385/65R x 22.5 Foam Filled Tires

120SXJ

At 120 feet (36.58 m), the Model 120SXJ offers the highest level of performance within the SX line. It features faster boom movement for improved operator efficiency, standard four-wheel drive with planetary reduction gear, standard four-wheel/crab steering and an exclusive Load Management Indicator System with audio/visual alert.

Features & Advantages

- Standard pin-less axle extension reduces time spent on machine setup
- Customer-preferred controls
- Standard 36 x 96 in. (0.91 x 2.44 m) platform provides comfortable work area
- Standard 13 ft. (4 m) Extend-A-Reach articulating jib for ease of platform positioning around obstacles
- Rugged square steel platform tubing for enhanced durability
- Inward swinging gate and low entry height for ease of entry
- Deutz F4L912 70 hp Engine
- 445/65R x 22.5 Foam Filled Tires

JLG MODELS 110SX & 110SXJ

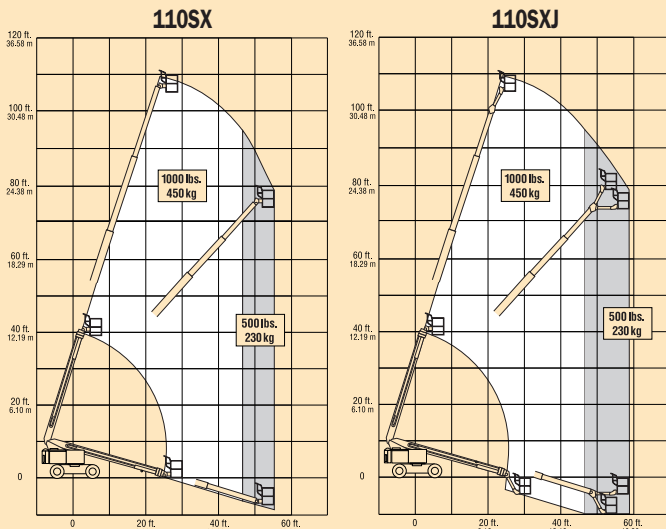

REACH SPECIFICATIONS

Platform Height	110 ft. (33.53 m)
Horizontal Outreach	60 ft. (18.29 m)
Below Ground Reach (110SX only)	12 ft. (3.6 m)
Swing	360° Continuous
Platform Capacity-Restricted (110SX)	1000 lbs. (450 kg)
Platform Capacity-Unrestricted	500 lbs. (230 kg)
Platform Rotator	180° Hydraulic
Jib (Range of Articulation) (110SXJ)	10 ft. (3.05 m) 90 degrees (+15, -75)

110SX

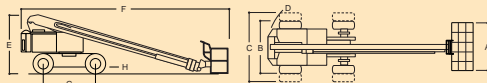

110SXJ

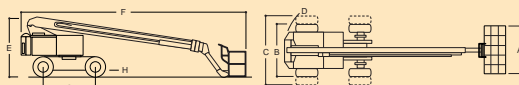

DIMENSIONAL DATA

A. Platform Size	36 x 96 in. (0.91 x 2.44 m)
B. Overall Width - Axles Retracted	8 ft. 2 in. (2.49 m)
C. Overall Width - Axles Extended	10 ft. 10 in. (3.3 m)
D. Tailswing (Axles Extended)	2 ft. 10 in. (86 cm)
E. Stowed Height	9 ft. 10 in. (3.0 m)
F. Stowed Length (110SX)	38 ft. 7 in. (11.76 m)
(110SXJ)	44 ft. 2 in. (13.46 m)
(110SXJ with full Jib)	44 ft. 11 in. (13.69 m)
G. Wheelbase	10 ft. (3.05 m)
H. Ground Clearance	14.5 in. (37 cm)
Gross Vehicle Weight* (110SX)	41,900 lbs. (19,006 kg)
(110SXJ)	41,400 lbs. (18,779 kg)
Max. Ground Bearing Pressure	177 psi (12.4 kg/cm ²)

CHASSIS

(Standard Two-Wheel Steer)

Drive Speed	3 mph (4.8 km/h)
Gradeability	40%
Turning Radius (Inside)	
Axles Retracted	14 ft. 8 in. (4.47 m)
Axles Extended	12 ft. (3.66 m)
Turning Radius (Outside)	
Axles Retracted	22 ft. 2 in. (6.76 m)
Axles Extended	24 ft. (7.32 m)
Tire Size/Type	385/65R x 22.5 Foam Filled

POWER SOURCE

Diesel Engine	Deutz F4L912 70 hp (52 kW)
Fuel Tank Capacity	26 gal. (98.4 L)
Hydraulic Reservoir	50 gal. (190 L)
Auxiliary Power	12V-DC

*Certain options or country standards will increase weight

JLG MODEL 120SXJ

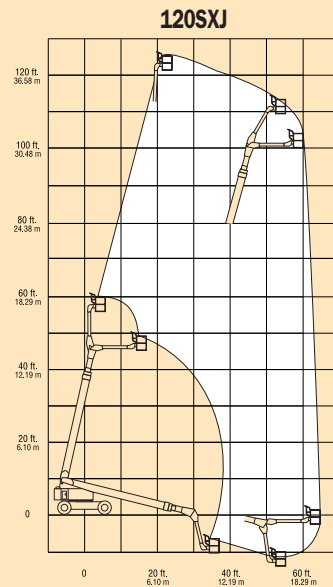

REACH SPECIFICATIONS

Platform Height	120 ft. (36.58 m)
Horizontal Outreach	60 ft. (18.29 m)
Swing	360° Continuous
Platform Capacity	500 lbs. (230 kg)
Platform Rotator	180° Hydraulic
Jib (Range of Articulation)	11 ft. (3.35 m) 90 degrees (+15, -75)

120SXJ

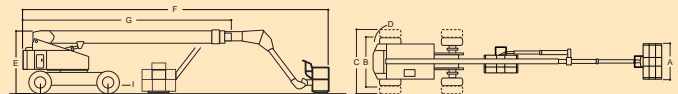

DIMENSIONAL DATA

A. Platform Size	36 x 96 in. (0.91 x 2.44 m)
B. Overall Width (Axles Retracted)	8 ft. 2 in. (2.49 m)
C. Overall Width (Axles Extended)	10 ft. 10 in. (3.3 m)
D. Tailswing (Axles Extended)	2 ft. 10 in. (86 cm)
E. Stowed Height	10 ft. (3.05 m)
F. Stowed Length (Working)	52 ft. 4 in. (15.95 m)
G. Stowed Length (Transport)	35 ft. 11 in. (10.95 m)
H. Wheelbase	10 ft. (3.05 m)
I. Ground Clearance	14.5 in. (37 cm)
Gross Vehicle Weight*	43,500 lbs. (19,732 kg)
Max. Ground Bearing Pressure	149 psi (10.5 kg/cm ²)

CHASSIS

(Standard Four-Wheel Steer)

Drive Speed	3 mph (4.8 km/h)
Gradeability	40%
Turning Radius (Inside)	
Axles Retracted	12 ft. 10 in. (3.91 m)
Axles Extended	10 ft. 7 in. (3.23 m)
Turning Radius (Outside)	
Axles Retracted	17 ft. 4 in. (5.28 m)
Axles Extended	18 ft. 10 in. (5.74 m)
Tire Size/Type	445/65R x 22.5 Foam Filled

POWER SOURCE

Diesel Engine	Deutz F4L912 70 hp (52 kW)
Fuel Tank Capacity	26 gal. (98.4 L)
Hydraulic Reservoir	50 gal. (190 L)
Auxiliary Power	12V-DC

*Certain options or country standards will increase weight

PERFORMANCE FEATURES



Standard Features

- Four-Wheel Drive
- Pin-less Axle Extension
- 36 x 96 in. (0.91 x 2.44 m)
Low Mount Platform
- Inward Swinging Gate
- 180 Degree Hydraulic Platform Rotator
- 110V-AC Receptacle On Platform
- 5 Degree Tilt Alarm/Indicator Light
- Rim Protector Lug Tread Tires
- 12V-DC Auxiliary Power
- Proportional Controls
- Lifting/Tie Down Lugs
- Hourmeter
- Horn
- Foam Filled Tires

1. Low oil pressure and high coolant temperature alarms.
2. Includes ether assist battery heater, oil manifold heater and oil tank heater.
3. Includes boom wiper seals, cylinder bellows, turntable shield and console cover.

Available Options

- 36 x 72 in. (0.91 x 1.83 m) Platform
- Platform Work Lights
- ½ in. (1.3 cm) Air Line to Platform
- "Soft Touch" System 6 ft./8 ft. (1.83 m/2.44 m)
- 2500W Generator
- Four-Wheel Steer
- Head and Tail Lights
- Front Chassis Jack
- Travel Alarm
- All Motion Alarm
- Flashing Amber Beacon
- 43.5 lb. (19.73 kg) Propane Tank
- Engine Distress Warning¹
- Cold Weather Start Kit (Deutz)²
- Hostile Environment Kit³

Flexible Financing

JLG offers the best combination of leasing and financing alternatives, tailored to individual needs and with cost-competitive financial products that make your choice of JLG equipment easier. We can handle every aspect of the loan or lease, including flexible end-of-term options and disposition. And, because we understand the market and your needs, we provide efficient service to process and provide approval of your application quickly.

The JLG "1 & 5" Warranty

JLG Industries, Inc. backs our products with our exclusive "1 & 5" Warranty. We provide coverage on all products for one (1) full year, and cover all specified major structural components for five (5) full years. Due to continuous product improvements, we reserve the right to make specification and/or equipment changes without prior notification. This machine meets or exceeds applicable OSHA Regulations in 29 CFR 1910.67, 29 CFR 1926.453, and ANSI A92.5-1992 as originally manufactured for intended applications.

The JLG Promise

Whether you rent or own a JLG lift, you can expect the best in terms of safety, reliability, productivity and ease of use for the operator.

See our product showcase at www.jlg.com/SX

JLG Industries, Inc.

1 JLG Drive
McConnellsburg, PA 17233-9553
Telephone 717-485-5161
Toll-free in US 877-JLG-LIFT
Fax 717-485-6417

